



TIGHTNESS CLASS



MATERIAL



BACTERIOSTATIC

Plenum Box

VPB125-2, VPB125-2/90

The AWENTA PRO plenum box is used to connect two flexible ducts to the distribution boxes. Thanks to the possibility of supplying two ducts, it is recommended for mounting air valves in rooms requiring balanced ventilation intended for daytime stays or bedrooms.

The AWENTA PRO plenum boxes are made of durable HDPE (High Density Polypropylene) with a bacteriostatic Nano-Silver additive. The robust structure guarantees failure-free operation for many years and thanks to the use of a bacteriostatic additive the product has obtained a very high level of bacteriostatic activity. The design of the plenum box allows it to be mounted on different surfaces and in different planes. The Ø75 or Ø90 mm female connectors are equipped with a gasket and special protection of the connected ducts, which ensures the tightness of the entire system in the high ATC1 class. Mounting of the box is facilitated by brackets allowing for the installation height adjustment that adapts to the place of installation. They guarantee the quick and easy installation of the plenum boxes in the system. The box allows for connecting a maximum of two Ø75 or Ø90 mm ventilation ducts to a supply or exhaust air valve.

It is possible to install them on floor / wall / ceiling: made of concrete or plasterboard.



VPB125-2

VPB125-2/90

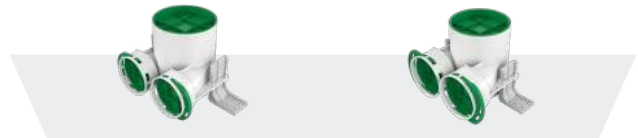

AIR FLOW CHARACTERISTICS

VPB125-2

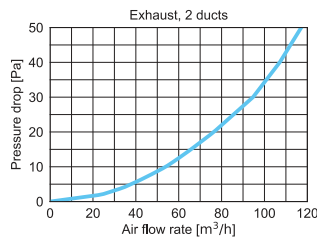
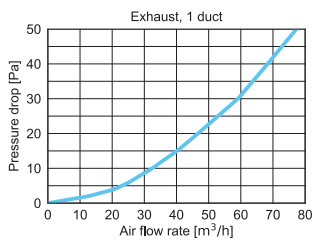
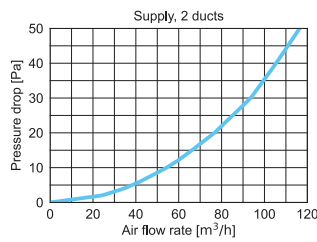
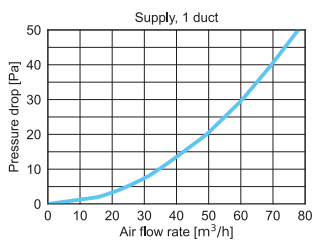

VPB125-2/90

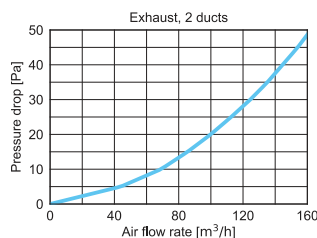
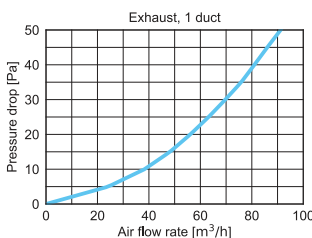
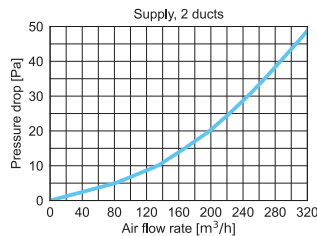
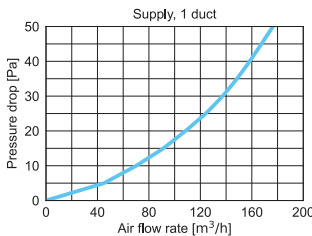

DIMENSIONS

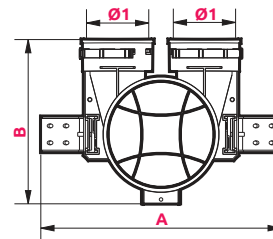
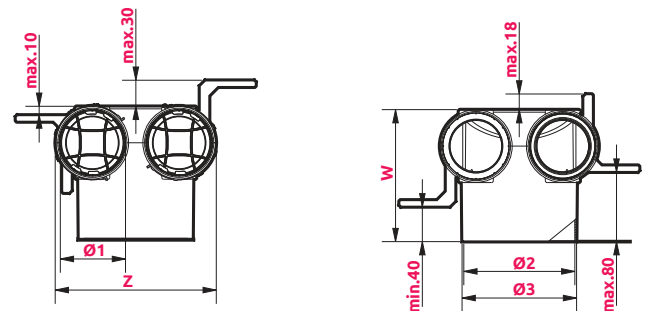

	Ø1	Ø2	Ø3	A	B	Z	W
VPB125-2	75	128	134	277	189	186	152
VPB125-2/90	90	128	134	288	202	200	158

WITH **NANOSILVER** ADDITIVE
ELIMINATING UP TO 99% BACTERIA

